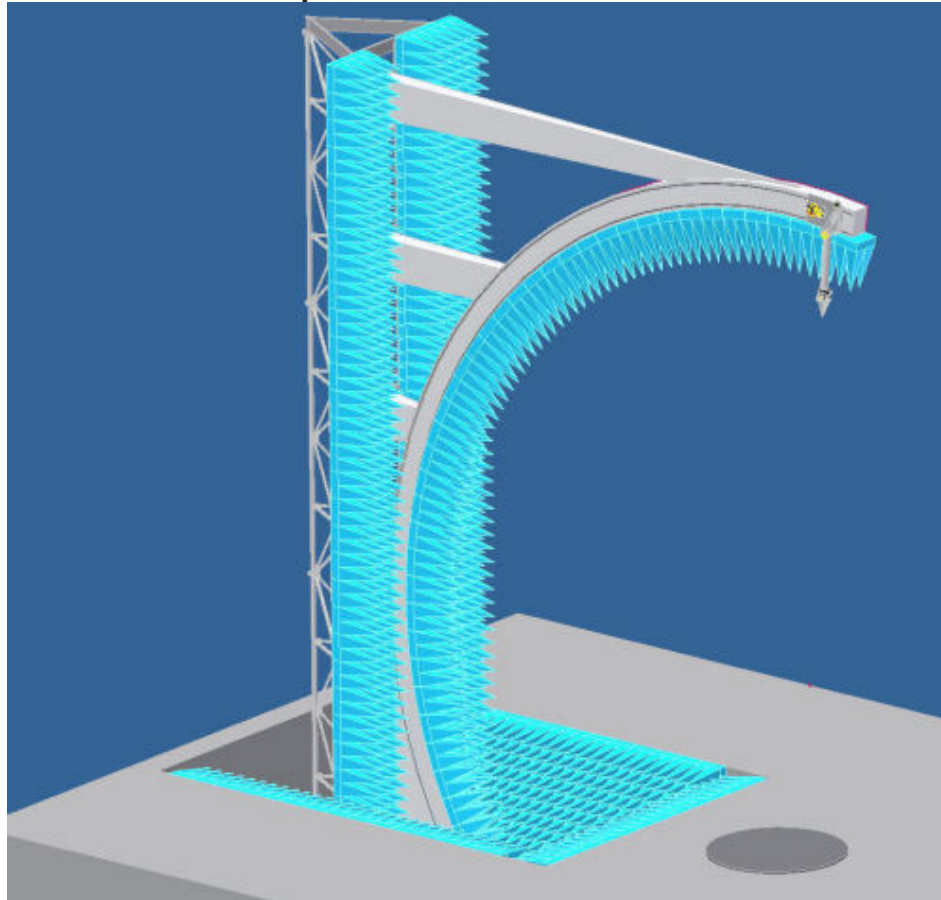

Spherical Near-field Arch Scanner**DESCRIPTION**

The NSI model 700S-400 is an ideal system for measuring radiation characteristics of vehicle mounted antennas. The system interfaces with a wide variety of NSI, Agilent, or Rohde & Schwarz RF equipment. The Model 700S-400 includes NSI's NSI 2000 Antenna Measurement Software. This software runs on a Windows based measurement workstation and provides automatic setup of scans based on measurement parameters and desired output. Measured data can be processed for far-field or holographic patterns yielding complete characterization of the antenna's performance. A single data set provides information on antenna gain, side lobe structure, beam pointing and cross polarization. The Model 700S-400 can be supplied with a variety of options to enhance system performance.

CAPABILITIES

The 700S-400 consists of a vehicle turntable and an overhead mechanical arch with scanning radius of 30 ft (9.1 m). The rotator can support loads up to 35,000 lb (15,900 kg) and can operate at speeds up to 12°/s. The arch is a steel semi-monocoque structure designed for stiffness, providing a solid base for the angular probe movement at up to 1°/s over a 135 degree span.

FEATURES

- Radiation Pattern Testing of Vehicle Mounted Antennas
- Scanning arch provides accurate probe motion over 135 degrees in theta
- In-ground turntable provides smooth 360 degree phi rotation of vehicle under test
- Automatic Electronic Alignment Capability
- Dual-Polarized Broadband Near-field Probe
- Dynamic on-the-fly Probe Position Correction Subsystem
- Multi-beam, Multi-Frequency Control of RF Subsystem
- NSI 2000 Data Acquisition & Processing Software

SPECIFICATIONS	
TURNTABLE	Diameter of 12 ft (3.7 m)
	35,000 lb (15,900 kg) load capability
	RF rotary joint & slip ring assembly
	Position accuracy of 0.01°
ARCH	Angular velocity of up to 12°/s (2 rpm)
	Probe scanning radius of 30 ft (9.1 m)
	Angular velocity of 1.0°/sec
	Angular positioning accuracy of 0.01°
NSI2000 SOFTWARE	Angular range from 0° to 135°
	Near-field acquisition and processing capability
	Multi-frequency capability
	MARS reflection suppression technique
	Supports all standard NSI instrument drivers

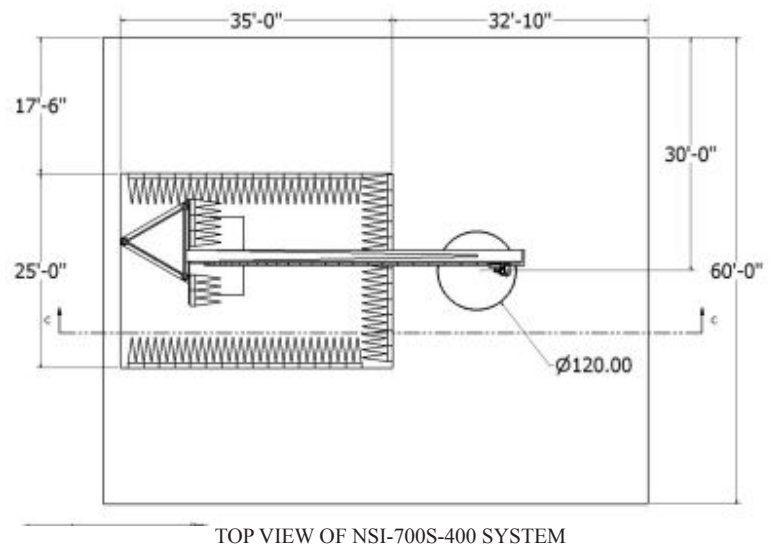
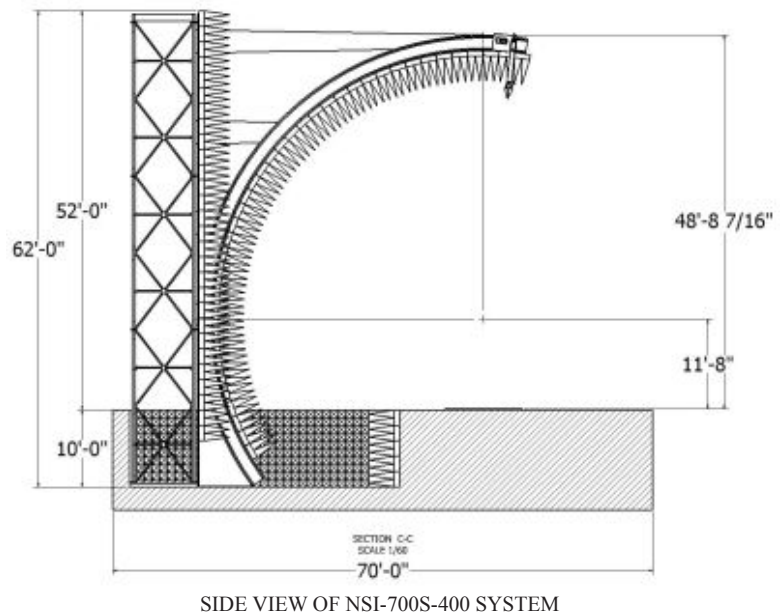

NSI Vehicle Turntable

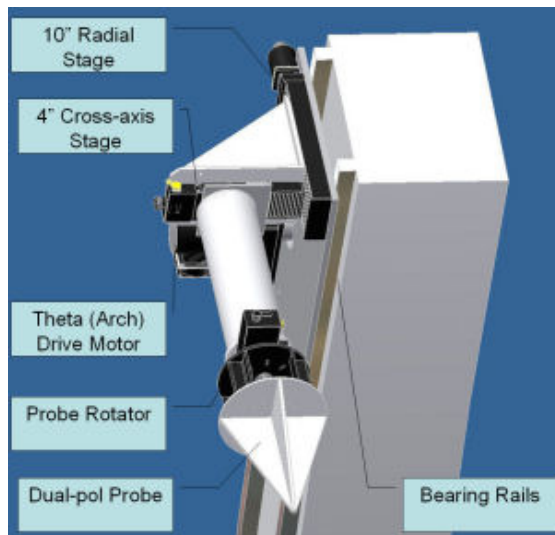

Dual-Polarized Probe to minimize test time
 Probe Carriage uses Radial and Cross-axis
 Stages for Dynamic Probe Position Correction

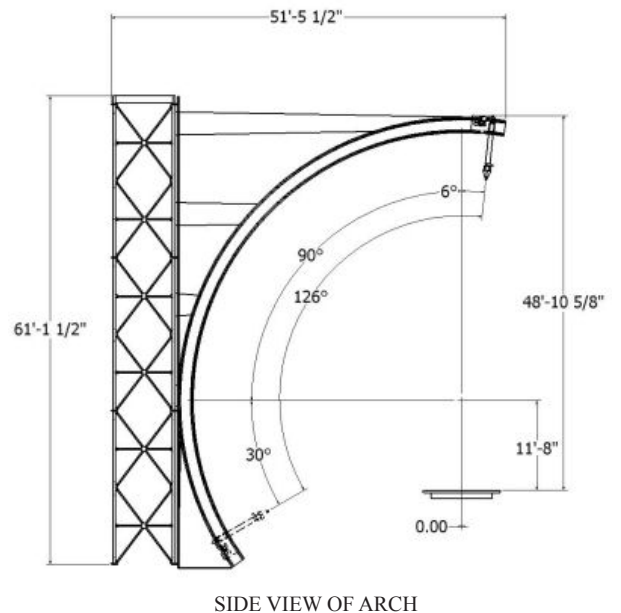

Nearfield Systems, Incorporated

19730 Magellan Drive, Torrance, CA 90502, USA, Tel: 310.525.7000, Fax: 310.525.7100
 Email: sales@nearfield.com. Visit our website: www.nearfield.com