

NSI-RF-5940

Distributed Frequency Converter, 1 GHz to 26.5 GHz

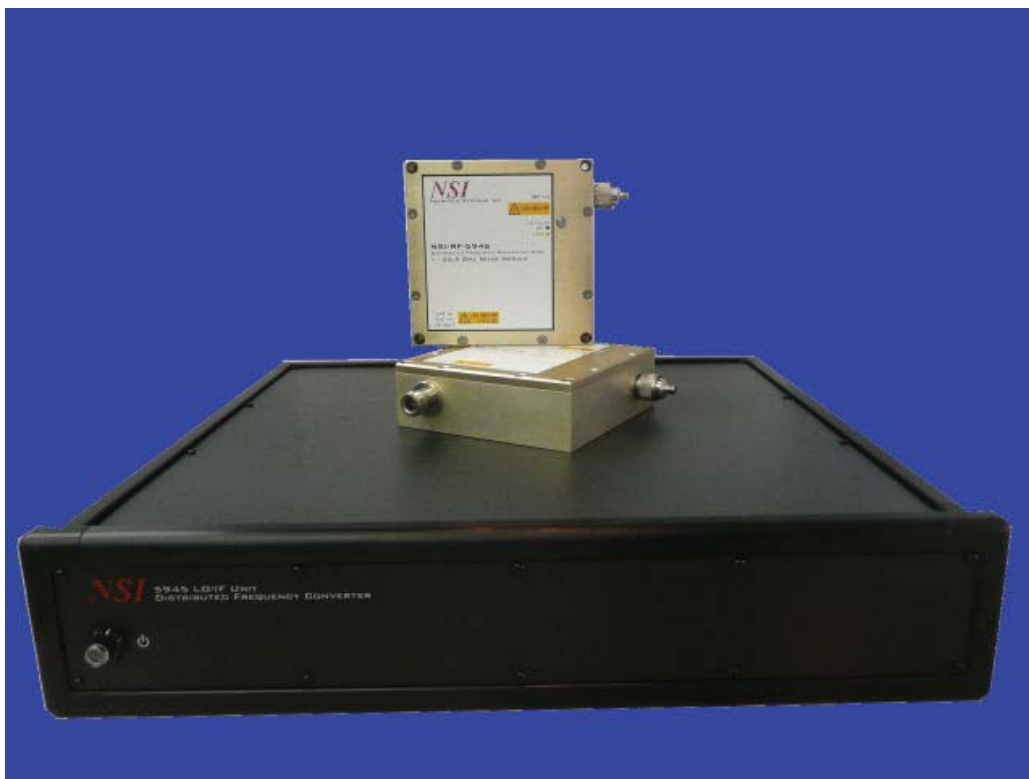

DESCRIPTION

The Distributed Frequency Converter (DFC) is designed to provide down-conversion of a test and a reference RF signal to a fixed 20 MHz or other IF signal, using remote mixer modules. The NSI-RF-5940 consists of an LO/IF unit and two 1-26.5 GHz mixer modules.

BLOCK DIAGRAM

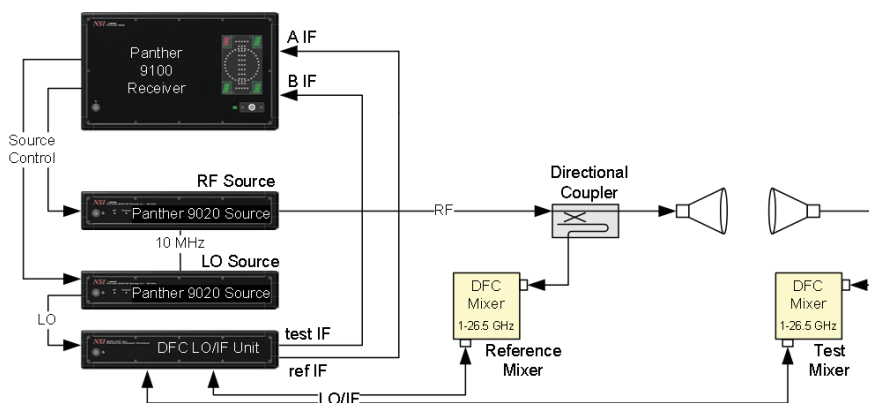

FEATURES

- ◆ Compatible with NSI Panther, Agilent 8530A and PNA receivers
- ◆ Microwave Mixer Module covers 1 GHz to 26.5 GHz
- ◆ Optional Mixer Modules provide frequency coverage as low as 100 MHz and as high as 50 GHz
- ◆ Supports LO cable lengths up to 120 feet at 18 GHz
- ◆ Fundamental mixing up to 20 GHz
- ◆ Test and reference mixer modules are identical and connect to LO/IF unit with a single cable
- ◆ Test and reference LO cables do not have to be of the same length
- ◆ Field-replaceable RF input connector

SPECIFICATIONS

DFC Model		NSI-RF-5940		
Frequency Range	1 to 26.5 GHz			
Nominal IF Frequency	5 - 20 MHz			
Nominal LO Input Power	5 dBm			
Maximum LO cable loss	35 dB			
Specifications for Fundamental Mixing (@2500 measurements per second)	Using Agilent 8530A receiver	Using NSI Panther receiver 9000 receiver	Using Agilent PNA (20MHz IF)	Using Agilent PNA (8.33 MHz IF)
Frequency Range	1 to 20 GHz	1 to 20 GHz	1 to 20 GHz	1 to 20 GHz
Maximum Test and Reference RF In Power (0.1 dB Compression)	-26 dBm	-29 dBm	-30 dBm	-24 dBm (with 20 dB IF attenuators)
Conversion Efficiency, RF In to IF Out	10 dB to 16 dB	10 dB to 16 dB	10 dB to 16 dB	10 dB to 16 dB
Sensitivity, S/N = 1	< -117 dBm	< -119 dBm	< -115 dBm	< -115 dBm
Dynamic Range				
Isolation, Reference to Test Channel				
Specifications for Third Harmonic Mixing (@2500 measurements per second)	Using Agilent 8530A receiver	Using NSI Panther receiver	Using Agilent PNA (20 MHz IF)	Using Agilent PNA (8.33 MHz IF)
Frequency Range	6 to 26.5 GHz	6 to 26.5 GHz	6 to 26.5 GHz	6 to 26.5 GHz
Maximum Test and Reference RF In Power (0.1 dB Compression)	-18 dBm	-21 dBm	-22 dBm	-15 dBm (with 20 dB IF attenuators)
Conversion Efficiency, RF In to IF Out	-1 dB to 8 dB	-1 dB to 8 dB	-1 dB to 8 dB	-1 dB to 8 dB
Sensitivity, S/N = 1	< -106 dBm	< -108 dBm	< -104 dBm	< -104 dBm
Dynamic Range	> 88 dB	> 87 dB	> 82 dB	> 89 dB
Isolation, Reference to Test Channel	> 100 dB	> 100 dB	> 100 dB	> 100 dB
Physical Characteristics - LO/IF Unit				
Height	3.5" (2 EIA Units)			
Width	17" (excluding rack adapter)			
Depth	16" (excluding handles)			
Power	100 - 240 V, 50/60 Hz, 35 W			
Physical Characteristics - Mixer Module				
Height	5" (excluding connector)			
Width	5" (excluding connector)			
Depth	1.7"			
Indicators	LO power OK/ Too Low LED			
Connectors	RF: 3.5 mm (f) standard, replaceable with other types; LO: N(f)			
Ordering Information				
NSI Part Number	Description			
NSI-RF-5940	Distributed Frequency Converter Set, 1 to 26.5 GHz. Consists of LO/IF Unit and two 1 to 26.5 GHz Mixer Modules	NSI-RF-5946	DFC, 1 to 26.5 GHz Mixer Module	
NSI-RF-5941	Distributed Frequency Converter Set, 0.1 to 6 GHz. Consists of LO/IF Unit and two 0.1 to 6 GHz Mixer Modules	NSI-RF-5947	DFC, 0.1 to 6 GHz Mixer Module	
NSI-RF-5942	Distributed Frequency Converter Set, 1 to 40 GHz. Consists of LO/IF Unit and two 1 to 40 GHz Mixer Modules	NSI-RF-5948	DFC, 1 to 40 GHz Mixer Module	
NSI-RF-5943	Distributed Frequency Converter Set, 1 to 50 GHz. Consists of LO/IF Unit and two 1 to 50 GHz Mixer Modules	NSI-RF-5950	DFC, 1 to 50 GHz Mixer Module	
NSI-RF-5945	DFC, LO/IF Unit			
Comparison between DFC and Agilent 85309A with 85320A/B mixers				
Specification	Agilent 85309A with 85320A/B		NSI DFC	
Frequency Range	2 to 26.5 GHz (usable to 1 GHz)		1 to 26.5 GHz	
Maximum LO frequency	18 GHz		20 GHz	
Maximum LO/IF Output Power	+23 dBm		+15 dBm	
Minimum Mixer LO Power	+8 dBm		-20 dBm	
Maximum allowable LO cable loss	15 dB		35 dB	
LO Cable length requirement	Test and Reference LO cable must have the same loss		No restrictions	

Nearfield Systems, Incorporated

19730 Magellan Drive, Torrance, CA 90502, USA, Tel: 310.525.7000, Fax: 310.525.7100
 Email: sales@nearfield.com. Visit our website: www.nearfield.com