

Greg Hindman
Nearfield Systems Inc.
1330 E. 223rd Street Bldg. 524
Glendale, CA 90232
(213) 518-4277

APPLICATIONS OF PORTABLE NEAR-FIELD ANTENNA MEASUREMENT SYSTEMS

ABSTRACT

Portable near-field measurement systems can provide significant flexibility to both large companies seeking to increase their antenna test capabilities, and small companies looking for their first investment in a test range. There are many unique applications for portable near-field antenna measurement systems in addition to their use for standard antenna performance measurements. Some additional applications include flightline testing, anechoic chamber quiet zone imaging, and EMI testing.

Many of NSI's near-field systems have been portable designs, capable of being set up in a small lab or office and easily relocated. Key features required for a portable system are rapid setup, simplicity of use, low cost, and accuracy. This paper will be focused on practical experience with installing, calibrating, and operating portable near-field measurement systems. It will also cover tradeoffs in their design, and usage in a variety of applications.

INTRODUCTION

Antenna test applications sometimes require that the measurement system be taken to the antenna, rather than the more common approach of taking the antenna to a large, permanently installed test system. Anechoic chamber imaging also dictates the need for relocatable equipment to map the quiet zone. Nearfield Systems Inc. has pioneered a new line of highly portable antenna and chamber measurement systems to address these problems. This paper will discuss the practical experience and design tradeoffs involved with taking near-field measurements on the road.

Major considerations involved with the implementation of a portable system will be discussed. Along with typical test configurations and test results achieved with portable systems. Following is a list of major considerations involved with...

- Portability, Shipping Weight And Size
- Accuracy
- Reliability
- Ease
- Cost

TEST APPLICATIONS

Antenna Performance Measurements

Planar near-field systems are ideal for medium to high gain antennas when most of the energy is radiated in the forward hemisphere, typically within ± 70 degrees.

For antennas which are directional in one plane and broad in the other, a cylindrical near-field measurement system is recommended. For antennas which are extremely broad or omnidirectional in both planes, a spherical near-field system is usually required. Figure 1 shows a Model 255 planar/cylindrical system implemented for Anaren Microwave. The XY scanner provides a 5' by 5' travel range for planar near-field measurements on directive antennas. The antenna under test is mounted on an azimuth rotator which remains fixed for planar testing and is moved in combination with the Y axis of the XY scanner to perform cylindrical near-field measurements.

- Test Applications

Another type of planar near-field system uses a plane-polar scanning geometry. Plane-polar scanning yields a circularly symmetric set of data points on a plane in front of the antenna aperture, and is ideal for

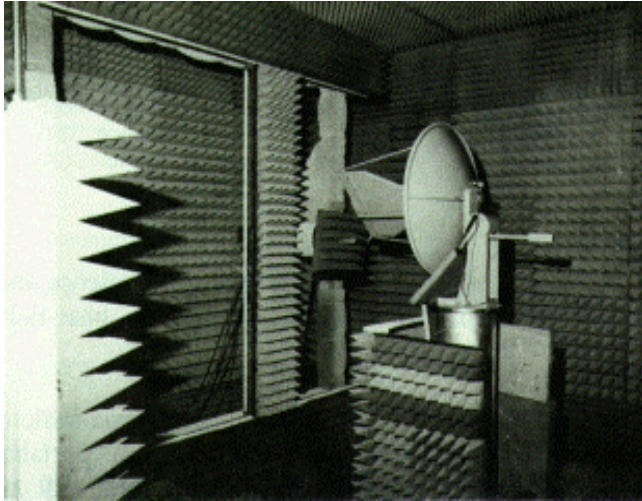

Figure 1 NSI 5' By 5' Planar/Cylindrical Near-Field System

antennas which have approximate circular symmetry in their radiation patterns. A large reduction in the number of data points required is often possible, which will significantly reduce data acquisition and processing time. NSI has used this scanning technique for numerous satellite dish antennas with excellent results. For these antennas, both axes of a cartesian XY scanner were driven simultaneously to provide continuous path motion of the probe along the radius cuts of the plane polar scan.

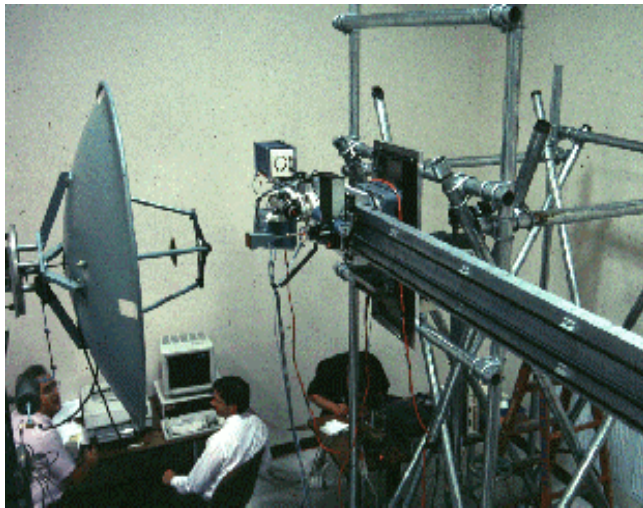

Figure 2 12' Diameter Plane-Polar System

A combination of probe linear motion and antenna under test rotation about its axis is often used to perform a plane-polar scan. This was the method

used by JPL for the Galileo 16' antenna. This method is sometimes referred to as the 'barbecue' method due to the antenna motion.

Allowing the antenna under test to remain motionless during testing is an advantage of using a cartesian XY scanner to perform the plane-polar scan. NSI has also built another type of plane-polar scanner which does not require antenna under test motion.

Figure 2 shows a 12' diameter plane-polar scanner which is implemented by rotating a 6' radius stage through a complete circle using a large rotary stage at one end, somewhat like a half bladed propeller. The probe is de-spun with a small rotary stage, keeping the probe polarization constant. This system was designed and built for the specific purpose of testing a customer's antenna which could not be moved to a test chamber, and would be difficult to rotate around its axis. In order to increase the accuracy of the scanner, an optical skeleton system was added to track the probe position errors (Slater, 1991). This system has subsequently been leased to two additional customers for performing antenna measurements and chamber quiet zone scanning. Table 1 summarizes the three methods used to perform plane-polar near-field measurements.

Scanner type	Hardware required	Advantages
Cartesian XY	XY scanner	No AUT motion Can take complete system to antenna More versatile
Plane-polar, barbecue method	AUT rotator Probe linear stage	Simple probe motion
Plane-polar, propeller method	Probe linear stage Rotary stage to spin linear stage	No AUT motion Can take complete system to antenna

Table 1 Methods of performing plane-polar measurements

CHAMBER DIAGNOSTICS

Portable near-field scanners are ideally suited for use in measuring the quiet zone performance of anechoic chambers and compact ranges. The 12' diameter plane-polar system described above was used by one large aerospace customer to calibrate the angle of arrival of the plane wave of multiple quiet zone areas from the compact range reflector system for subsequent satellite antenna testing. NSI's small 2' by 2' scanner has also been used to diagnose the quiet zone of an anechoic chamber. Contrary to popular belief, the quiet zone does not need to be completely mapped to derive useful results. Sampling a smaller area of the quiet zone and using a windowing function to taper the data, allows chamber reflection performance to be evaluated using SAR imaging techniques.

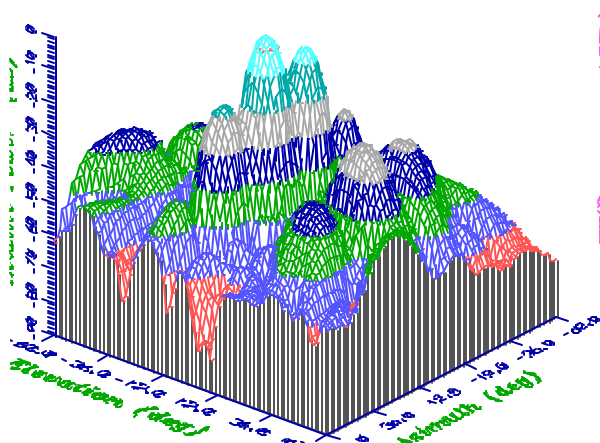

Figure 3 Anechoic Chamber Reflections

Figure 3 shows a 3D waterfall image of a chamber with numerous defects. The tallest peak is the desired signal from the illumination horn. The peak next to it is a severe RF leakage in the receiving system. The other lower peaks represent reflections from a support structure on the floor and a light fixture in the ceiling. Analysis of this type of plot can lead to corrective action such as adding isolation in the receiving system and improving the placement of absorber. The end result will be an anechoic chamber which provides more accurate antenna measurements.

PORTABILITY

NSI has designed and implemented numerous portable systems with linear dimensions ranging from 2' to 20'. Several of the systems are dedicated to lease applications and have been easily transported and set up many times. Following is a list of primary considerations of importance for each application.

- Shipping weight, size
- Movement through customer's doors, elevators
- Floor stability at test site
- Absorber requirements
- Interface to customer equipment

Shipping and Setup Information - NSI Model 255

Shipping Weights, Sizes

- Scanner 400 Lbs 8'x8'x2' Crate
- Computer system 156 Lbs 3 Boxes
- HP8510C VNA system, 224 Lbs 4 Boxes

- Typical shipping cost \$500
- Setup time after delivery 4 Hours
- Z-Plane alignment test 1-2 Hours

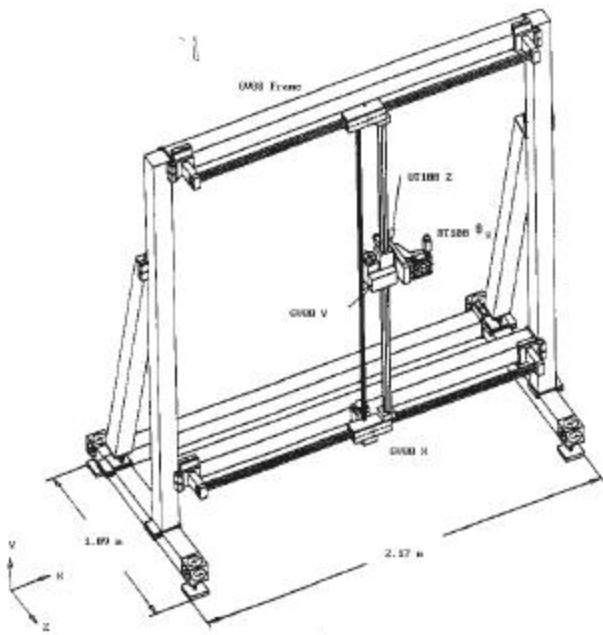

Figure 4 NSI 255 scanner isometric

Figure 4 is an isometric view of a typical scanner. Its modular design allows easy setup and operation.

MEASUREMENT ACCURACY

Careful attention to detail can provide excellent results with portable near-field systems. One of the largest potential error sources is multipath interference, which can be fairly high when testing antennas in the absence of an anechoic chamber. Another important error source to characterize is the scanner accuracy, since the typical portable system is prone to larger structural errors than a similarly sized permanent installation. Fortunately, techniques exist to help minimize the effects of these errors.

Multipath Suppression

Multipath reflections can induce large errors in sidelobe measurements if ignored. Techniques for identifying multipath in a test system include measurements at multiple Z distances, testing the antenna under test in different orientations, and performing time domain measurements. Time gating

can be applied in some cases to eliminate the unwanted reflections, however there is usually a severe penalty in data acquisition time, and the antenna must be reasonably broadband. Traditional methods of dealing with multipath have included averaging data sets from multiple tests with different antenna to probe separations, however these can also significantly increase test time. Careful analysis of the nature of the multipath can allow explicit steps to be taken to effectively eliminate the errors in many cases. A technique developed by NSI (Hindman, 1989) provides reduction of the sidelobe noise floor due to multipath to -50dB by measuring near-field

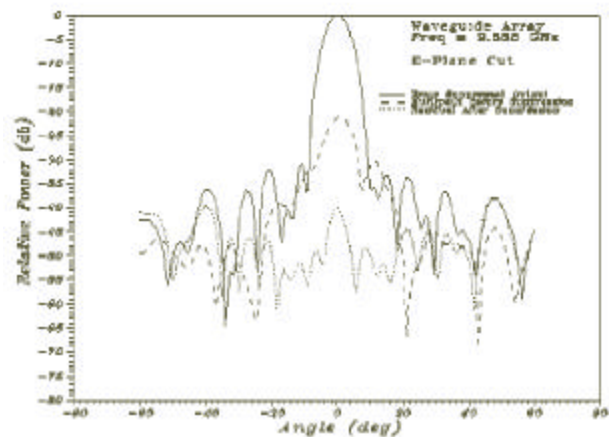

Figure 5 Multipath suppression

data on two Zplanes separated in space by $1/4\lambda$. Figure 5 shows the multipath energy spectrum before suppression, the residual multipath after suppression, and the error corrected antenna pattern. The technique is particularly useful for portable and leased systems which are not always used in an anechoic chamber.

Scanner Structure Calibration

Probe positioning accuracy of a typical portable 5' by 5' system is on the order of 0.005" RMS. The pattern error introduced by this position error is quite small for most applications and can be included in the overall uncertainty budget. For applications requiring higher accuracy, the system can be calibrated using optical techniques to map the errors into a lookup table, and using interpolation between points, or by augmenting the system with a real-time optical monitoring skeleton (Slater, 1991). The first approach works quite well when the system is used in a stable environment. Figure 5 shows the scanner error map from one of NSI's model 244 scanners. Table 2 shows the expected sidelobe errors from a 5 mil RMS scanner due to the uncalibrated scanner errors and what can be expected due to residual errors after calibration for a typical X-band antenna.

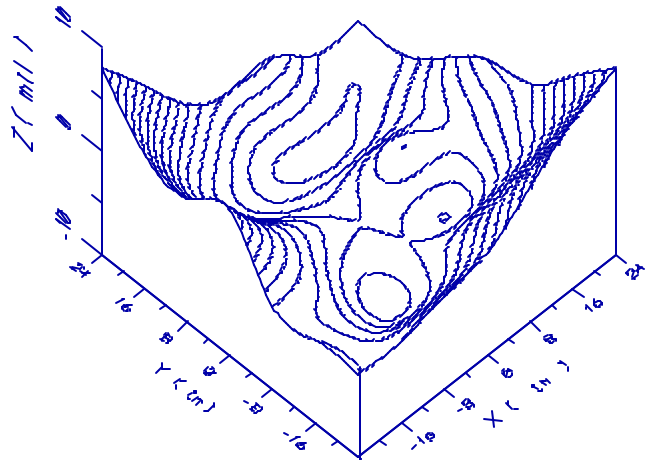

Figure 6 Scanner Z-plane errors

Sidelobe level	Freq = 12 GHz	
	Uncalibrated	Calibrated
±20 dB	0.2	0.1
±30 dB	0.5	0.2
±40 dB	1.9	0.7
±50 dB	+4/-9	2.5

Table Sidelobe uncertainty due to 5 mil RMS Z plane errors

EASE OF USE

Portable systems are ideally suited for short term lease applications, and must therefore be designed to be set up and operated by relatively inexperienced users. The hardware setup should be able to be performed by two or three technicians with standard tools.

NSI uses a structured and logical software menu system which is both flexible and convenient. Expert system concepts are used to guide the user through test design, equipment setup, data acquisition and data processing steps. Clear, complete system and software documentation is also a key element.

RELIABILITY AND COST

Increased reliability in portable systems can result from minimizing the overall number of components in the system. This can also significantly reduce the system cost. As an example, the computer is used to directly generate the pulses which command the stepper motors, eliminating the need for a complex and costly smart controller. Since stepper motors can be controlled quite reliably without encoder or synchro feedback (which is typically found in antenna measurement systems), these can also be eliminated.

NSI's development of a receiver post-processor (Slater, 1991) also follows this general philosophy. A simple, phase modulated interferometer (PMI) with very few components can be used to provide accurate near-field measurements, by performing software corrections to the data using Hilbert transform techniques. Figure 7 shows a portable system with

NSI's PMI receiver interfaced to the Comstron FS2000B synthesizer.

CONCLUSION

This paper has discussed numerous design and operational considerations for portable near-field antenna measurement systems. Versatile, low cost systems can be implemented without sacrificing performance, by using appropriate design techniques.

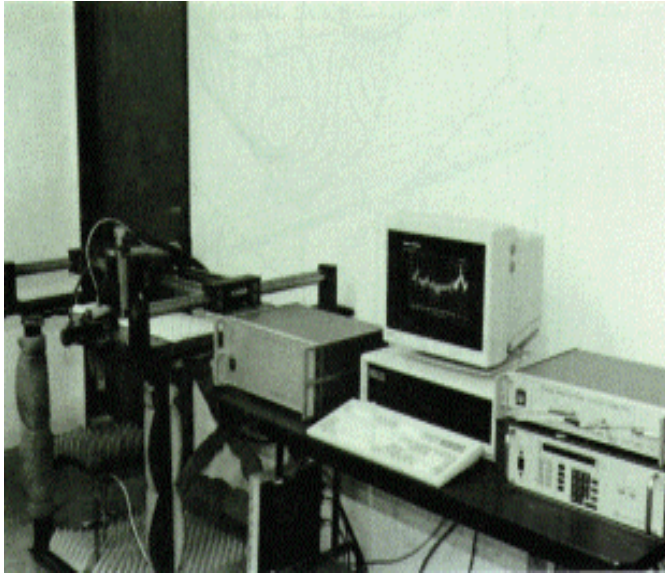

Figure 7 *Portable System And Phase Modulated Interferometer*

REFERENCES

Slater, D. Near-Field Antenna Measurements, Artech House, Norwood, MA, 1991

Book includes a complete chapter on robotics with section on optical skeleton systems used for real time monitoring of scanner positioning errors.

Hindman, G. and Slater, D. Error Suppression Techniques for Near-Field Antenna Measurements, 1989 AMTA Symposium

Paper discusses use of techniques for minimizing multipath effects on near-field ranges.

Slater, D. A Hilbert Transform Based Receiver Post Processor, 1991 AMTA Symposium

Paper describes a software based receiver post processor that corrects gain and circularity errors in coherent receivers.