

THE IMPLEMENTATION OF A SPHERICAL NEAR-FIELD MEASUREMENT SYSTEM IN MAINLAND CHINA

Greg Hindman, Hanjian, Wei-Bin Ye

Nearfield Systems Inc.
1330 E. 223rd Street Bldg. 524
Carson, CA 90745 USA

Southwest China Research Institute of Electronic Equipment
Box 429, Chengdu 610036
China

Hewlett Packard, China
22/F, No.39 Daye Mansion Daye Road
Chengdu, 610016
China

ABSTRACT

Far-field range testing has been the standard at the Southwest China Research Institute of Electronic Equipment (SWIEE) and at other facilities in mainland China. SWIEE has recently commissioned a new spherical near-field measurement system from Nearfield Systems Inc. (NSI) and Hewlett Packard (HP) to improve its antenna measurement capability. The near-field system provides significant advantages over the older far-field testing including elimination of weather problems with outdoor range testing, complete characterization of the antenna, and improved accuracy. This paper will discuss the antenna types at SWIEE tested with the NSI/HP near-field system, and the results being achieved.

Keywords: Antenna Measurements, Near-Field, Measurements, Spherical Near-field.

1. Introduction

The spherical near-field range was chosen because of the need by SWIEE to test a wide variety of antennas with varying gains and beamwidths. Planar and cylindrical scanner options were considered as well, but ruled out due to their scan angle limitations in one or both directions. The spherical system can measure almost a complete sphere of data except as limited by the pattern blockage from the PHI axis rotator and mount for the AUT. The NSI spherical scanner allows measurements of antennas up to 2.0 meters in diameter and up to 136Kg.

The Hewlett Packard RF subsystem provided the coherent amplitude and phase measurements necessary for the spherical near-field to far-field transformation process, based on the NIST spherical transformation software included with the NSI software control program.

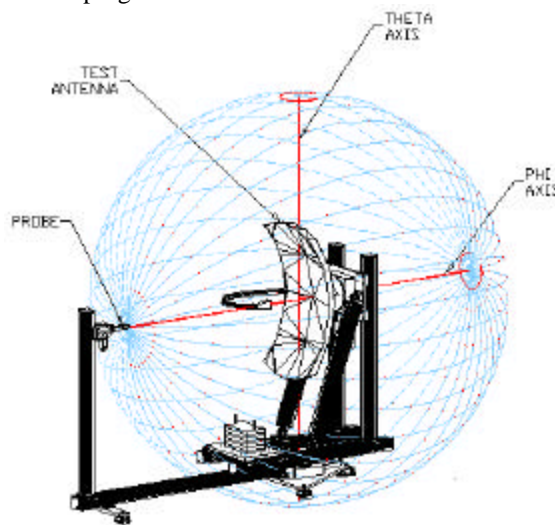

Figure 1 Spherical Measurement System

2. Range Configuration

The near-field range consists of the usual subsystems and each will be described in sequence:

- 1- RF subsystem
- 2- Robotic subsystem
- 3- Computational subsystem

2.1 RF Subsystem

The RF subsystem is based on an HP 85301C network analyzer. This unit was chosen since it can work well for both antenna tests and network analyzer measurements with minor changes. Figure 2 shows the network analyzer and computer system with the spherical scanner in the background. The system uses an HP 8530A receiver, HP 8511A frequency converter, and an HP 83631A RF source. The RF subsystem equipment and probes, allow measurements from 2 to 18 GHz.



Figure 2 HP 85301C Network Analyzer

The block diagram of the RF subsystem is shown in Figure 3. 18 GHz rotary joints are used in the Azimuth and Phi rotators to allow continuous rotation without the need to worry about RF cable flexure.

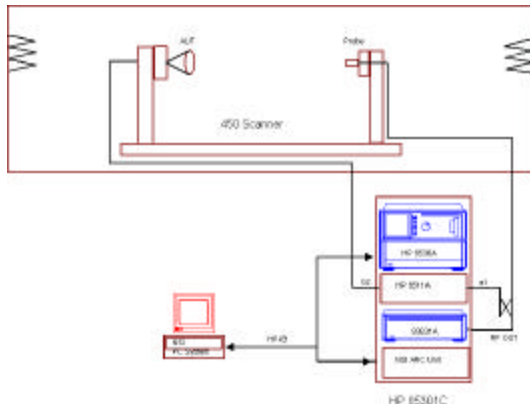

Figure 3 - RF Subsystem Block Diagram

2.2 Robotic Subsystem

The Robotic subsystem chosen was NSI's model 450 Spherical Near-field Measurement System. The system uses a PHI-over-Azimuth positioner configuration and allows measurement of antennas up to 2 meters. The PHI and Azimuth positioners are actually identical, and connected with modular extruded aluminum tubing which provides a stiff yet lightweight structure. The NSI model 450 is designed as a portable scanner, but can also be permanently mounted to the ground as was done in the SWIEE system using the triangular base mount and adjustable feet grouted into the floor.

The following figure shows the model 450 scanner system. The PHI stage and its angled support structure can be translated in the Z direction to accommodate AUT's of different lengths. At the opposite end from the PHI stage is the counterbalance system which balances the weight of the PHI stage and vertical supports, and has adjustable weights to accommodate antennas up to the maximum load of 136 Kg.



Figure 4 NSI Model 450 Spherical Scanner

2.3 Computational Subsystem

The computational subsystem uses NSI's Spherical Nearfield Control software, operating on a Pentium 100 MHz PC. The software is designed to allow the operator to define a minimal set of test parameters for the antenna, and then to automatically configure all remaining parameters required for a successful test.

Figure 1 shows the spherical surface used for measurements on one type of SWIEE antenna, the cut paraboloid. The software can acquire the data in either Azimuth cuts or PHI cuts as selected by the operator. Dual polarization measurements are required for the spherical transformation process, and a computer-

controlled probe pol axis is used. First, a complete set of E_0 measurement data is acquired with horizontal probe polarization, then a complete set of E_0 measurement data is acquired with vertical probe polarization.

The NIST spherical transformation software is used to process the data. This software from NIST is called directly from the NSI control software using the standard NIST data and control files. The following figure shows the program flow.

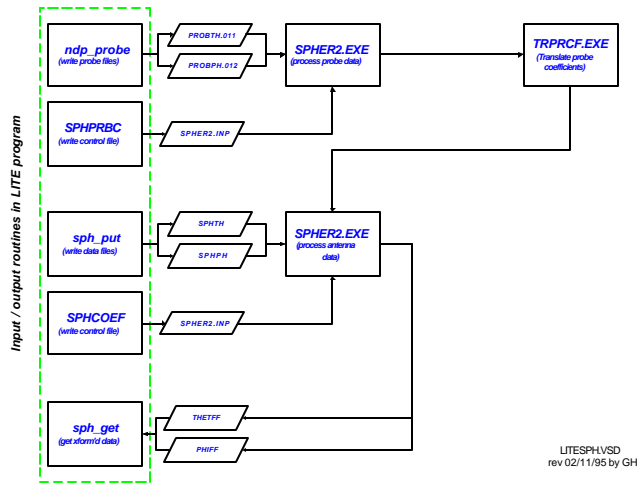

Figure 5 NSI Software Interface to NIST Program

The near-field software can provide 3D patterns, 2D contour plots, grey scale images, pattern cuts in linear and polar form, and data listings for near-field, far-field, and hologram diagnostic modes.

3. Installation and alignment

The triangular base of the Azimuth positioner and the base for the probe tower were installed by grouting special adjusters into the floor. The system rotators were then aligned using a combination of mechanical levels, water level, and laser calibration tool built specifically for the alignment of portable systems in the field (see figure 6). This procedure, developed and tested by NSI on numerous spherical systems delivered to customers, allows the alignment to be performed in the field without the need to transport heavy and expensive optical tooling equipment and alignment stands to remote locations.

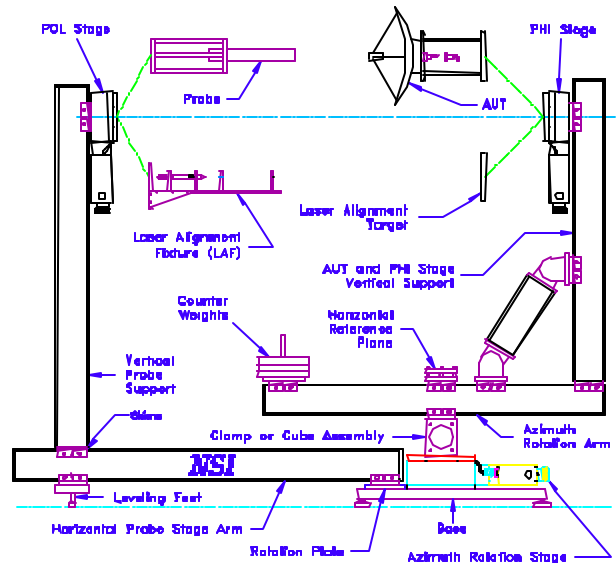

Figure 6 Spherical System Alignment Diagram

The laser alignment fixture can be used to check coning of both the PHI axis and probe POL axis. A small, inexpensive pen laser is aligned in the fixture and then rotated while observing the beam on a target at a relatively long distance, reachable with the water level. A typical accuracy achievable for leveling and orthogonality of axes is about $\pm 0.03^\circ$ (3.175mm laser beam coning radius at about 5.5m - see Figure 7).

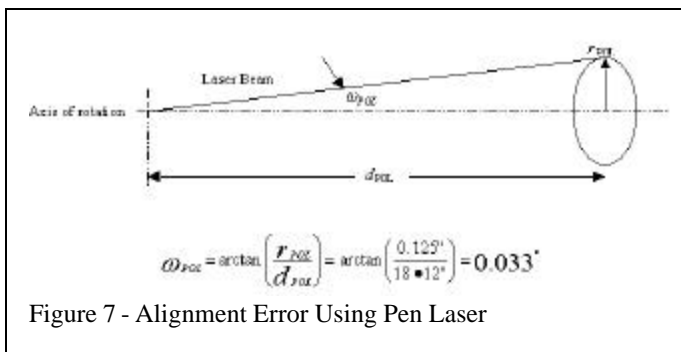

Figure 7 - Alignment Error Using Pen Laser

In addition to the mechanical alignment, NSI has developed an electrical alignment procedure which can be used to check and adjust some of the key alignments even after the probe and antenna are installed. This is described in a companion 1997 AMTA paper by Newell, Hindman - [The Alignment of a Spherical Near-Field Rotator Using Electrical Measurements.](#)

4. Test Results

The following data set was measured on a high gain antenna. The spherical near-field system can be used to measure the main beam as well as the sidelobes out 90 degrees and beyond. This can be a significant advantage over a planar NF system which is typically limited to about $\pm 70^\circ$. The spherical NF system can measure almost the full 360° coverage, but the backlobe of the pattern is typically blocked by the PHI positioner and AUT mount in the PHI-over Azimuth positioner configuration, limiting the spherical azimuth coverage to about $\pm 160^\circ$

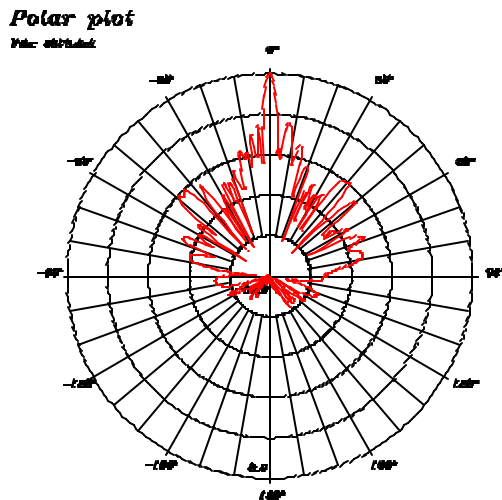

Figure 8 High Gain Antenna Pattern

The following data set was measured on a bi-conical antenna, which provides nearly omni-directional coverage except near boresight in the forward direction, and in the backlobe direction. This type of antenna can not be measured on a planar or cylindrical NF range due to the large truncation error which will occur.

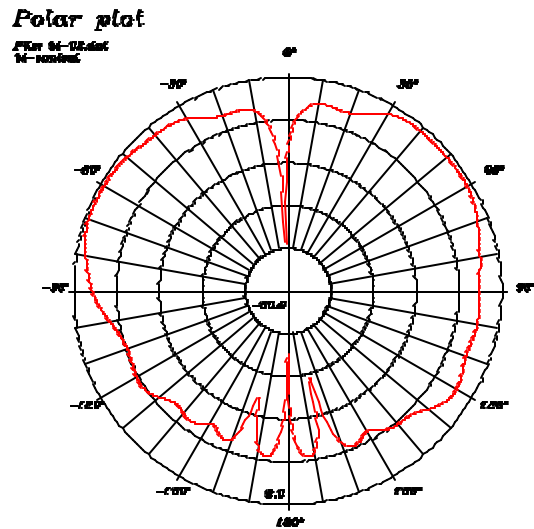

Figure 9 Broadbeam Bi-Conical Antenna Pattern

5. Conclusions

A spherical near-field measurement system has been commissioned at the Southwest China Research Institute of Electronic Equipment (SWIEE) for use in antenna measurements. SWIEE has used the system successfully to test a large variety of antennas including omni-directional antennas, ridge horns with wide beam widths, bi-conical antennas, multi-beam antennas, paraboloids, and standard gain horns.

References

- Hansen, J. E., Editor (1988) Spherical Near-Field Antenna Measurements, Section 5.3.3, London: Peregrines
- Wittmann , R. C., Stubenrauch, C. F., (1990) Spherical Near-Field Scanning: Experimental and Theoretical Studies, National Institute of Standards and Technology (US) NISTIR 3955
- Slater, D., (1991) Near-field Antenna Measurements, Artech House, Boston
- Way, J. and Haner, K. (1994) A Low Cost Spherical Near-Field System 1994 Antenna Measurement Techniques Association Proceedings
- Newell, A.C., and Hindman, G.H. (1997) The Alignment of a Spherical Near-Field Rotator Using Electrical Measurements, 1997 Antenna Measurement Techniques Association Proceedings