

HAND HELD MICROWAVE REFLECTOMETER

Antenna Measurement Techniques
Association Conference
October 9-13, 1989

Dan Slater / Greg Hindman
Nearfield Systems Incorporated
1330 E. 223rd Street #524
Carson, CA 90745 USA
(310) 525-7000

ABSTRACT

Measurements of the microwave reflectivity of materials is often performed with complex test setups using probes attached to a vector network analyzer. The lack of portability of these systems prevents the user from measuring reflective properties of surfaces that are not easily moved to an appropriate test facility. This paper describes a small, hand held microwave reflectometer which is designed to perform rapid reflectivity measurements in the field. The reflectometer consists of a tuneable Ku band source, a dual polarization sampling horn, a pair of crystal detectors, and a battery powered microcomputer.

Keywords: Reflectivity, mesh, hand-held

1. INTRODUCTION

Performance degradation of antennas with mesh reflecting surfaces has been observed when exposed to ambient environments during spacecraft integration activities. Typical methods used to monitor the degradation in mesh reflectivities include nearfield or farfield gain measurements, 2-horn transmission loss measurements, and reflection loss measurements. This paper describes a Hand Held Microwave Reflectometer (HHMR) designed to allow extremely rapid measurements of material reflectivity and environmental degradation effects.

2. BASIC DESIGN REQUIREMENTS

Listed below are the requirements which drove the development of the reflectometer unit.

1. Self contained and highly portable.

2. Perform measurements at various Ku band frequencies.
3. Compatible with fragile materials including assessment of correct contact with the material.
4. Repeatable to within +/- 0.2 dB for 0 to 2 dB reflection loss.
5. Measurement sets can be printed or downloaded to an optional external IBM PC computer.

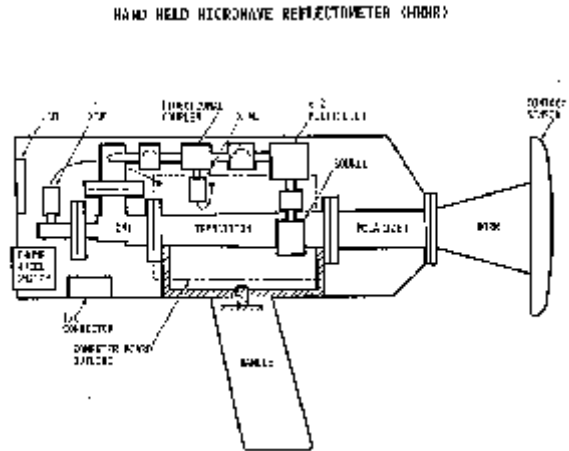

Figure 1 - HHMR Design

3. HHMR SUBSYSTEMS

The HHMR consists of five primary subsystems which will be described in the following sections:

1. Microwave subsystem
2. Penetration monitor
3. Power subsystem
4. Skeletal structure
5. Computational subsystem

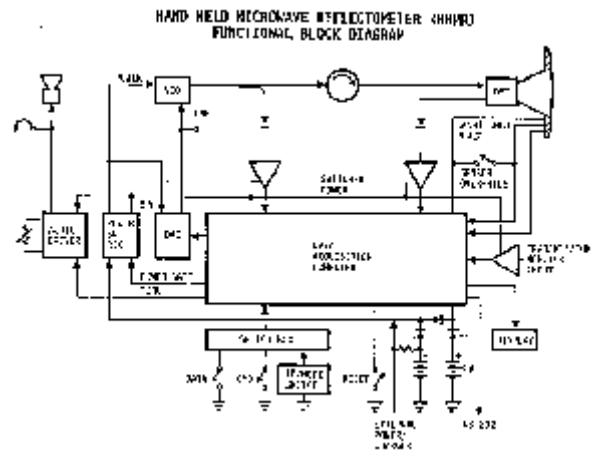

Figure 2 - Functional Block Diagram

3.1 MICROWAVE SUBSYSTEM

The microwave subsystem uses a small C-band voltage tuneable transistor oscillator with a frequency doubler providing an output of several milliwatts tuneable between 13.5 and 14.5 GHz. The source frequency is computer controlled. The power requirements are 35 ma at 9 VDC. The output of the oscillator is passed through isolators to a CP horn and to a crystal detector for monitoring source transmit power.

The reflectivity is measured by transmitting a Left Handed Circularly Polarized (LHCP) signal and measuring the reflected Right Handed Circularly Polarized (RHCP) signal. The polarization sense is reversed by the reflection. The two circular polarization senses are derived from the polarizer by using the two orthogonal linear polarizations generated by the Ortho Mode Transducer (OMT).

Reflected power output from the OMT is measured by a crystal detector connected to the computer through a preamplifier and analog to digital converter. In a similar manner, transmission through the material can be measured by an optional second horn and detector.

3.2 PENETRATION MONITOR

A correct and repeatable contact with the material under test is required for measurement accuracy and repeatability. As significant VSWR interaction effects are present, the need for repeatability is of extreme importance. The HHMR penetration monitor is used to insure that the material is in correct contact without overpressure.

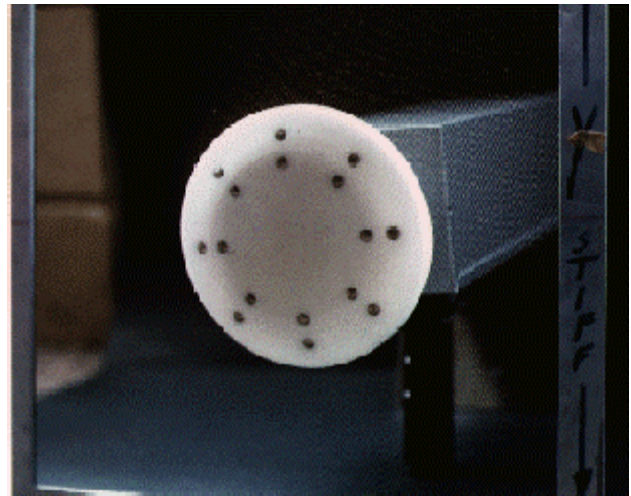

Figure 3 - Penetration Monitor

Because the HHMR is used to measure the properties of conductive materials, correct contact is readily determined by an electrical conductivity sensor. This sensor consists of a series of electrical contacts imbedded as 2 segmented rings in the teflon horn cover. Correct pressure is indicated by electrical contact between all segments on the inner contact ring. Excessive pressure or poor orientation is indicated by electrical contact between the inner ring and the slightly recessed outer ring. Penetration cues to the operator are aural so that the operator is not visually distracted. The computer additionally uses penetration information to accept valid and reject invalid measurements.

3.3 POWER SUBSYSTEM

Because the HHMR is battery operated, a power management subsystem is highly desirable. The power supply is a pair of standard 9 volt transistor radio batteries. The power management subsystem concept is very similar to those used in spacecraft. Because of power management efficiency in this application, the batteries often last many days. The power management subsystem includes an analog to digital converter (shared with the RF measurements) and a series of FET switches which control power routing to the various subsystems. The computer is never turned off but instead is powered down to a very low current level (200 ua) allowing the memory to remain valid for many months. The ADC allows the computer to monitor both battery voltages, switch batteries, and perform load shedding as the batteries become weak. As an example, the RF source uses the most power (35 ma) so that it is turned on only for the measurement interval.

3.4 SKELETAL STRUCTURE

Because the HHMR, as a hand held unit must be a light weight design, the structural and mass properties are of some importance. The long CP probe antenna serves as the primary structural element. As the unit was being developed, a weight budget was established in a manner similar to that used in aircraft and spacecraft design. The resulting weight of the unit was just under 6 pounds.

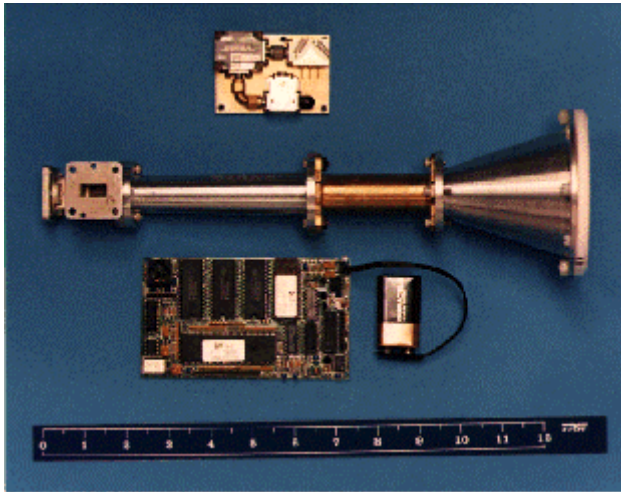

Figure 4 - HHMR Components

3.5 COMPUTATIONAL SUBSYSTEM

The HHMR is controlled by a small onboard computer. The computer uses a 6303 processor with 96 KB RAM and 32 KB EPROM. The computer includes RS-232 communications, bit serial communications, and an 8 bit ADC.

The computer performs the following functions:

1. Test sequencing
2. RF source frequency linearization and control
3. RF sensor power linearization and calibration
4. Measurement processing
5. Temporary measurement storage
6. Report generation
7. Power management
8. Maintenance support

The software program uses a menu driven state space program architecture as described by Slater⁽¹⁾. Communications to the operator are through a power efficient 2 line, 16 character LCD display and a variable frequency tone generator. The tone generator allows the operator to concentrate visually on the test region while listening for tones indicating

correct contact, overpressure warnings, and reflectivity pass/fail criteria if desired.

Communications from the operator are through a series of 3 bidirectional switches.

4. APPLICATIONS

Because the HHMR is heavily software based, it is readily adaptable to changing and emerging requirements. As an example, the HHMR supports a wide variety of measurement plans. Examples include:

1. Measure reflectivity at a specific point. Display the result immediately to the operator.
2. Compute the average reflectivity and variance of a series of measurements made while the probe is in motion across the mesh surface of an antenna. Reject all points with incorrect contact. Display the intermediate results immediately to the operator during the course of the measurement sequence.
3. Determine the average reflectivity and variance at 3 frequencies for a series of systematically determined positions. Provide these values in real time to the operator. Later output a summary and exception list to a small portable printer.
4. Record the microwave transmission at 10 frequencies every 30 seconds. Transfer the data to an IBM PC.

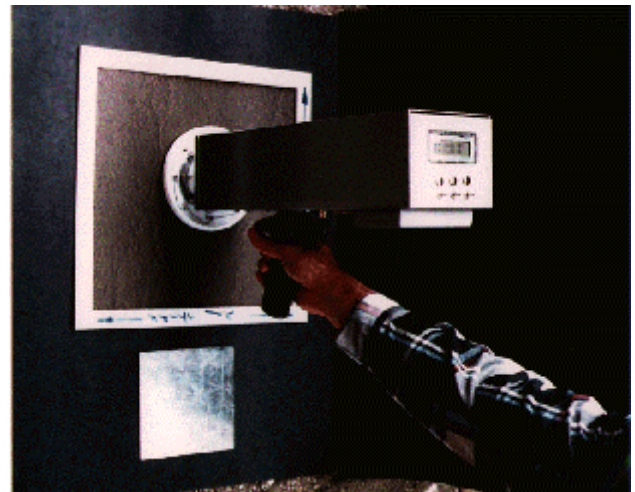

Figure 5 - HHMR Testing Mesh Panel

