

12' (3.7 m) Cylindrical Near-field Measurement System

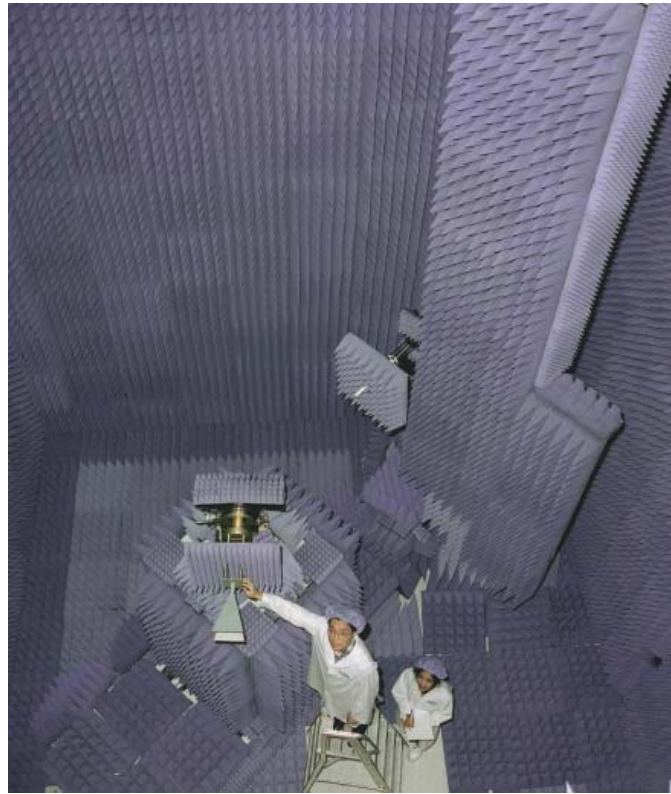

DESCRIPTION

Model 600C-12 is a complete cylindrical near-field system ideal for measuring broad-beam (azimuth) antennas with apertures less than twelve feet making it ideal for testing stacked linear arrays. The 600C-12 consists of a vertical probe tower with an 12' (3.7 m) travel, high capacity stepper motor based azimuth positioner, control computer, software and cabling. The high capacity probe stage can accommodate probes as large as a WR1500 including optional roll and translation stages. This simple design is easy to assemble and align.

CAPABILITIES

The system interfaces with a wide variety of RF equipment and is capable of measuring amplitude and phase patterns from L-band to mmWave Bands. The system includes NSI Antenna Measurement Software.

The system software runs on a Pentium based measurement workstation and provides automatic setup of scans based on measurement parameters and desired output. Measured data can be processed for far-field or holographic patterns yielding complete characterization of the antenna's performance. A single data set provides information on antenna gain, side lobe structure, beam pointing and cross polarization.

The Model 600C-12 can be supplied with a variety of options to enhance system performance.

FEATURES

- High Accuracy Y Linearity <math><0.004''</math> (0.10 mm) RMS
- 360° x 12' (3.7 m) Cylindrical Scan Area
- Precision Rack and Pinion Drive
- L-band to mmWave Measurements
- 4,400 lbs (1,996 kg) load capacity Az positioner
- Far-field, Near-field and Holographic Patterns

SPECIFICATIONS	
Construction	Steel tower and base; separate azimuth stage
Drive system	Precision Stepper Motor; Rack and pinion
Scan Area	360° in azimuth; 12' (3.7 m) Y
Y-axis Linearity Uncorrected	<0.003" (0.076 mm) RMS
Resolution	0.01° azimuth; 0.001" (0.025 mm) Y
Position Repeatability	0.03° azimuth; 0.002" (0.05 mm) Y RMS
Scan Speed	20°/sec azimuth; 15 in/s (0.38 m/s) Y
Azimuth Stage Axial Load	4,400 lbs. (1,996 kg) max.
Probe Carriage Capacity	125 lbs (56.8 kg) maximum recommended, WR1500
System Controller	NSI controller with serial and parallel I/O interfaces
Measurement Workstation	Measurement workstation computer with large LCD monitor.
Stepper Motor Power Amplifier	EIA 19" rack mount. (7" high x 14" deep) .
Motor Cables	Quick-connect; 40' (12 m)
Scanner Absorber	Absorber Kit (12" pyramidal cone)
Probe	WR90 Open-ended Waveguide Probe SMA (f) transition & Pyramidal absorber (3")
Probe Absorber	Pyramidal Cone Absorber (8")
Probe Mount	Angle Bracket - allows mounting probe in "V" or "H" orientation
RF Cables	Qty. 4 - Flexible 15' (4.5 m) with SMA (m-m) coaxial terminations; DC-18 GHz
Rotary Joint	Qty. 1 DC-18 GHz on Az stage
Supported RF Devices	NSI Panther Receiver Subsystem or selection of Agilent, Rohde & Schwarz and Anritsu VNA's (contact NSI for a complete list)
Power	100-240 VAC switchable, 47-63 Hz, 500 watts

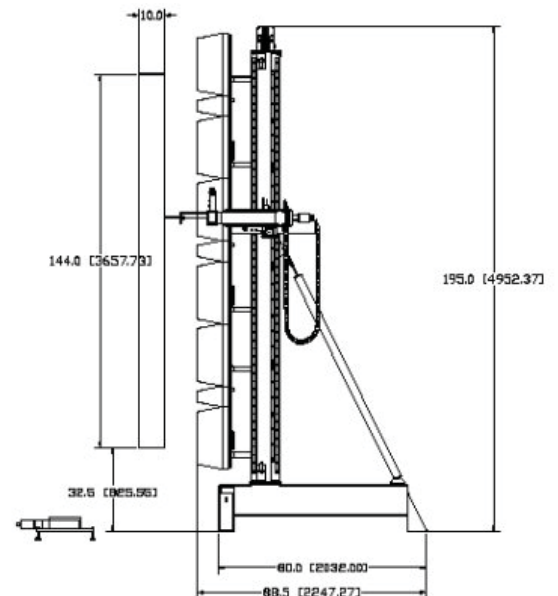
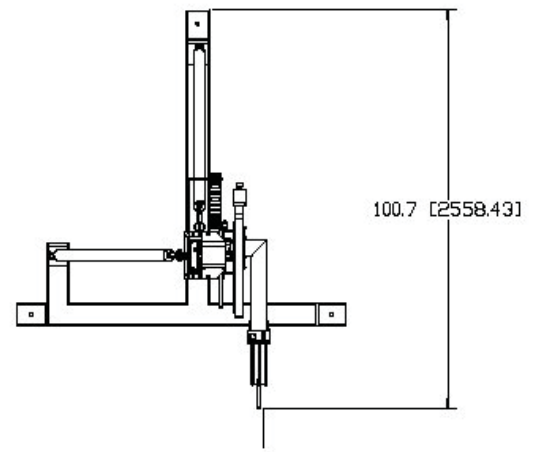

DIMENSIONS

- ◆ Width - 63" (1600.2 m)
- ◆ Depth - 73" (1844.0 m)
- ◆ Height - 195.0" (5000m)
- ◆ System Weight - 1,500 lbs. (680 kg) approx.

ORDERING INFORMATION

Please contact the NSI Sales department to order this product.

Nearfield Systems, Incorporated

19730 Magellan Drive, Torrance, CA 90502, USA, Tel: 310.525.7000, Fax: 310.525.7100
 Email: sales@nearfield.com. Visit our website: www.nearfield.com