

NSI-700S-70

Spherical Near-field Measurement System - 118 " (3.0 m) max AUT Dimension



DESCRIPTION

Model 700S-70 is an ideal system for measuring medium and low gain antennas up to 118 inches (3 m) in diameter and is ideally suited to perform cellular and PCS band base-station antenna testing. The 700S-70 uses a dual-axis phi-over-theta high accuracy stepper motor based positioning system with an adjustable extension foot for probe support. The system is constructed of modular high strength aluminum and can support loads of up to 300 pounds (136 kg). The location of the probe is adjustable to accommodate different configurations.

CAPABILITIES

The system interfaces with a wide variety of RF equipment and is capable of measuring amplitude and phase patterns from L-band to mmWave Bands. The Model 700S-70 includes NSI Antenna Measurement Software.

The system software runs on a Pentium based measurement workstation and provides automatic setup of scans based on measurement parameters and desired output. Measured data can be processed for far-field or holographic patterns yielding complete characterization of the antenna's performance. A single data set provides information on antenna gain, side lobe structure, beam pointing and cross polarization.

The Model 700S-70 can be supplied with a variety of options to enhance system performance.

FEATURES

- Full 360° Scan Area
- L-band to mmWave Band Measurements
- Automatic Electronic Alignment Capability
- Automatic Electronic Alignment Capability
- Far-field, Holographic and Near-field Patterns
- Far-field Measurement Options Available

SPECIFICATIONS	
Construction	Theta, phi, and pol rotation stages with "L" bracket (aluminum)
Drive system	Precision Stepper Motors
Scan Area	Full spherical; Phi/Theta - 360°
Maximum Antenna Load	300 lb (136 kg) at 9" CG off set
Maximum Antenna Diameter:	118 in (3 m)
Resolution	0.01° phi and theta
Position Repeatability	0.03°
Rotational Speed (Theta and Phi)	20°/sec Phi, 30°/sec Theta
System Controller	NSI controller with serial and parallel I/O interfaces
Measurement Workstation	Measurement workstation computer with large LCD monitor
Stepper Motor Power Amplifier	EIA 19" rack mount. (7" high x 14" deep)
Motor Cables	Quick-connect; 40' (12 m)
Scanner Absorber	Absorber Kit (5" pyramidal cone)
Probe	WR90 Open-ended Waveguide Probe SMA (f) transition & Pyramidal absorber (3")
RF Cables	20 GHz RF Cables
Rotary Joints	Qty. 3 - DC-26.5 GHz, (Phi, Theta, Pol)
Supported RF Devices	NSI Panther Receiver Subsystem or selection of Agilent, Rohde & Schwarz and Anritsu VNA's (contact NSI for a complete list)
Power	100-240 VAC switchable, 47-63 Hz, 500 watts

Front View

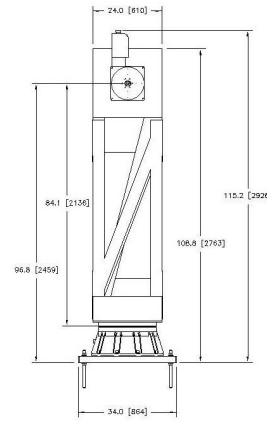

Side View

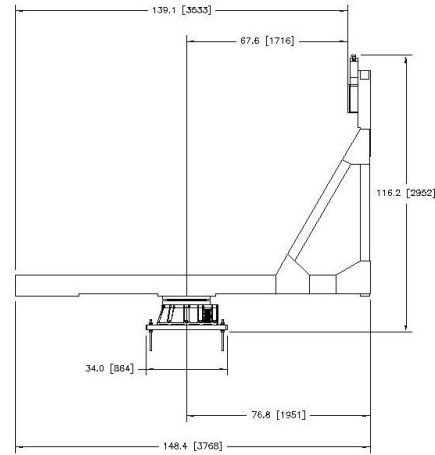

Top View

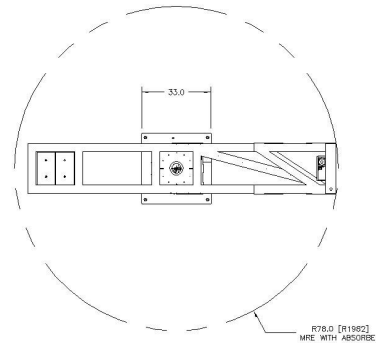

DIMENSIONS

- ◆ Width - 106" (2.7 m)
- ◆ Depth - variable
- ◆ Height - 116" (2.9 m)
- ◆ Weight - 2,500 lbs (1,090 kg)

ORDERING INFORMATION

Please contact the NSI Sales department to order this product.

Nearfield Systems, Incorporated

19730 Magellan Drive, Torrance, CA 90502, USA, Tel: 310.525.7000, Fax: 310.525.7100
 Email: sales@nearfield.com. Visit our website: www.nearfield.com